



注意力

おうちの方へ 茶色がないときは、似たような色でぬりましょう。

		なまえ
がつ	にち	



したの くだものを きって、みほんとおなじ えになるように、はりましょう。

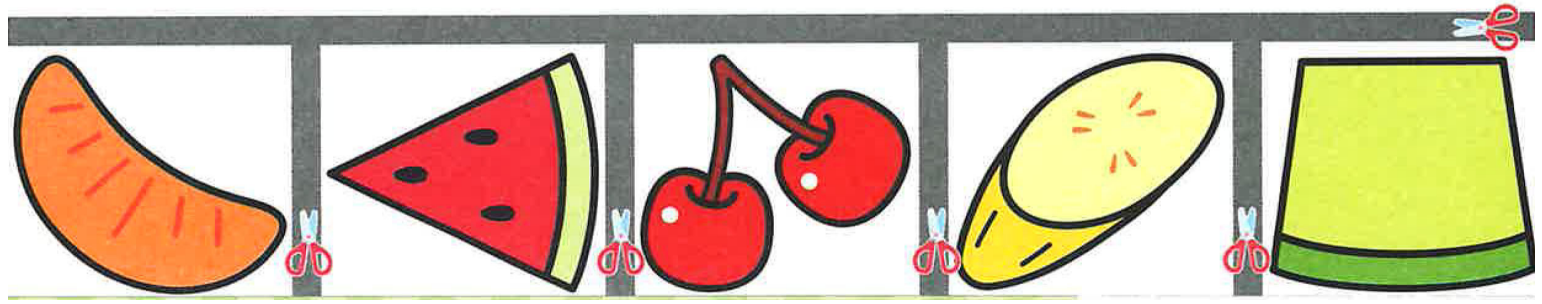

がっ	にち	なまえ
----	----	-----



「て」「と」「き」を なぞりましょう。それぞれの
もじで はじまる ものの ○に、いろを めってね。



せみ



てんとうむし

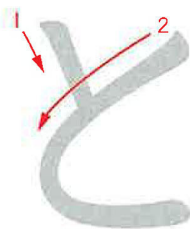

とんぼ



くわがたむし

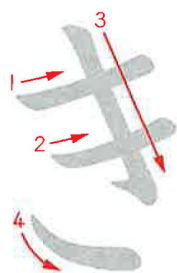
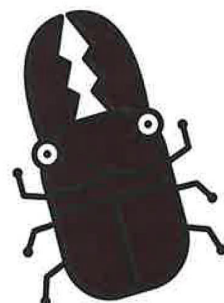

きつね

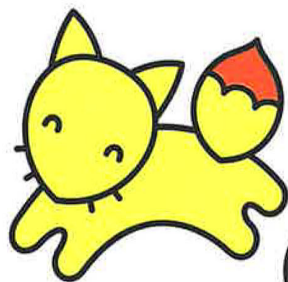

たぬき





		なまえ
がつ	にち	



すうじと おなじ かずの たべものは どれかな？
 せんで つなぎましょう。

なぞりましょう。

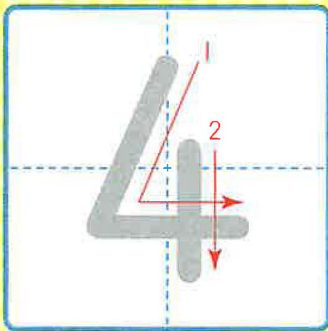

なぞりましょう。

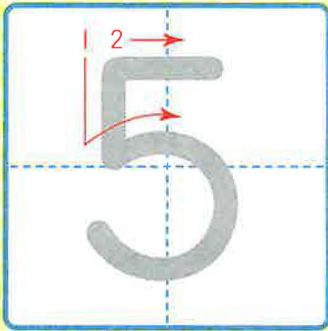

なぞりましょう。

